

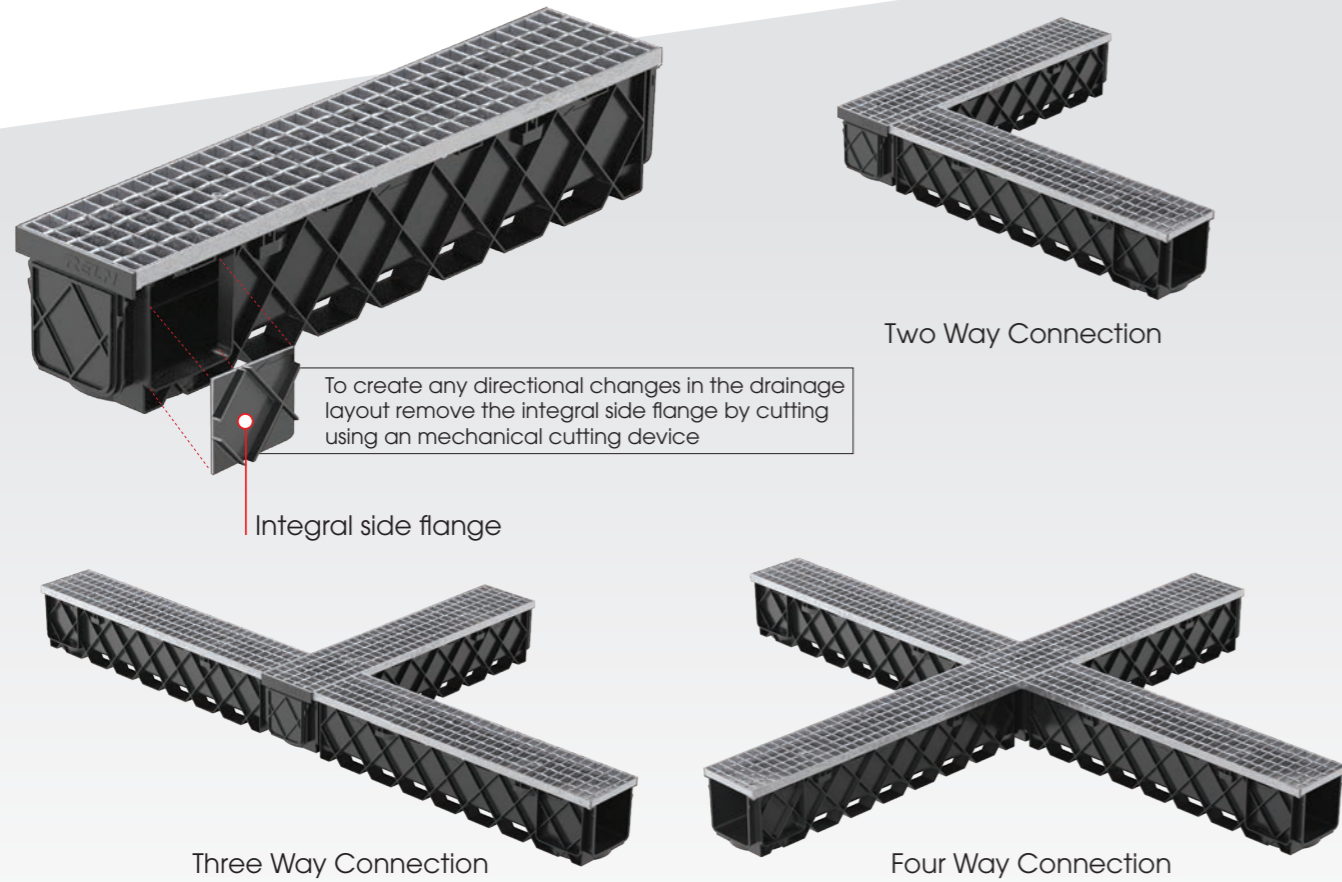

Innovative design with trade professionals in mind

Storm Drain Pro™ Series 100 - 150

The Storm Drain Pro™ Series 100 and Series 150 integral side flange allows easy change of direction into a two way, three way and four way connection.



Storm Drain Pro™ Series 200

The Storm Drain Pro™ Series 200 features a corner to allow for change of direction, as well as an inline pit for a complete drainage solution.

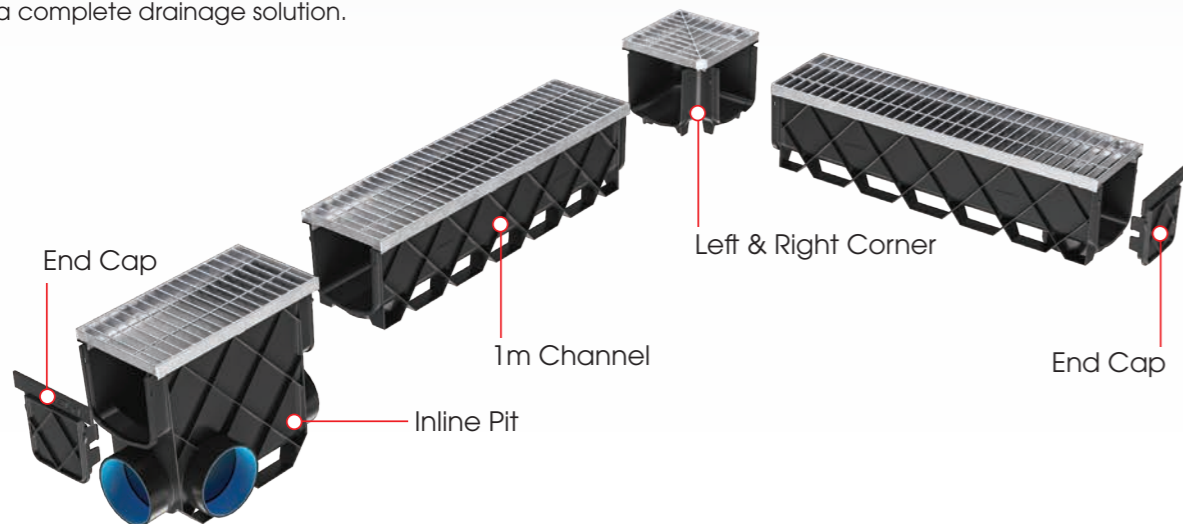

Trade Range Series 100

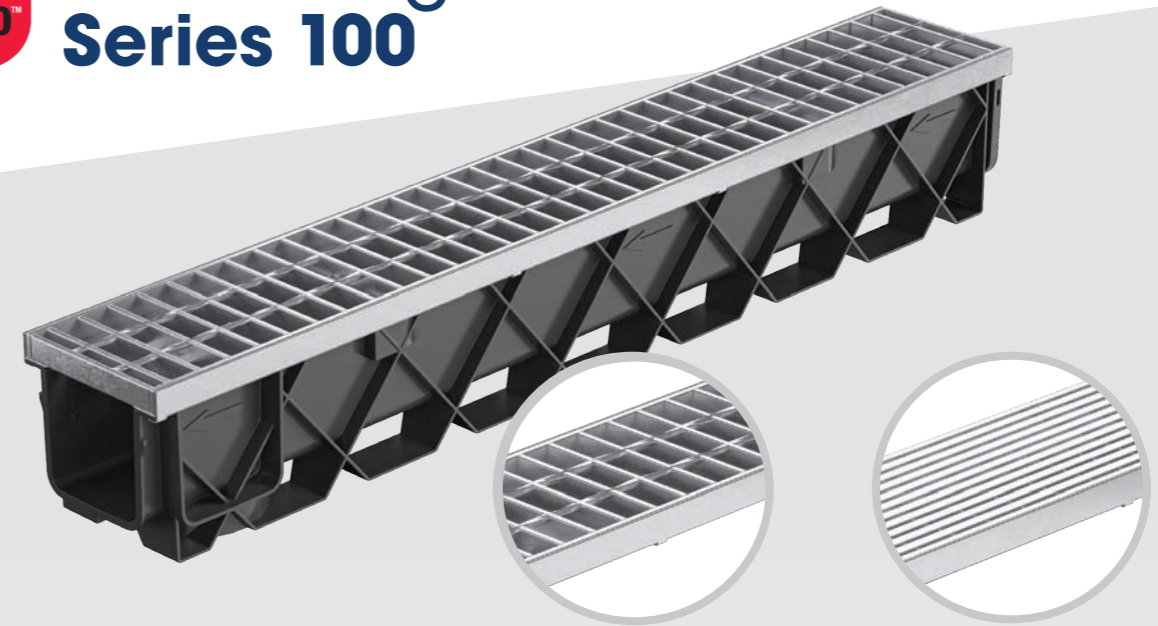

RELN Storm Drain Pro™ Series 100 is perfect for large domestic and light commercial applications. With its large 100mm profile, Storm Drain Pro™ effectively collects and distributes substantial volumes of surface water throughout its system. The channels innovative design features an integral side flange to create corners and intersections, removing the need to source additional fittings.

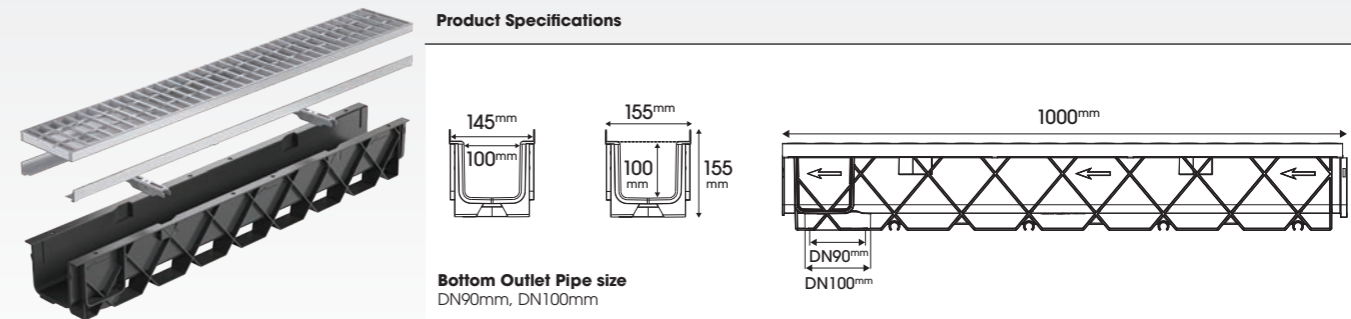

Series 100 1m Channel c/w Gal Class B Grate
Product Code: 210041
Series 100 1m Channel c/w H/Guard Class B Grate
Product Code: 210043

5
YEAR
CHANNEL

1
YEAR
GRATE

**PRODUCT
WARRANTY**

**100%
UV STABILISED
RECYCLED PLASTIC**

Product Accessories



Atrium Leaf Guard
Product Code: 003410

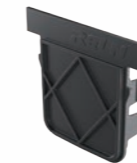

Series 100 End Cap
Product Code: 210039



Trade Range Series 150

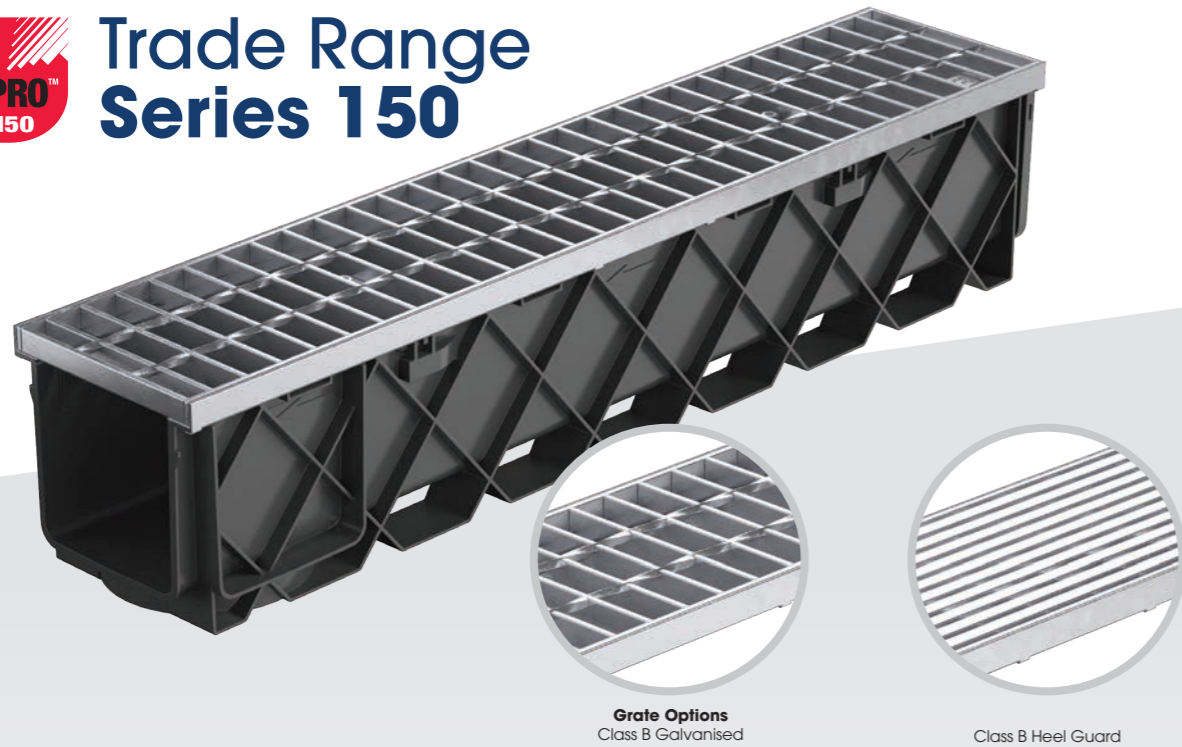

Grate Options
Class B Galvanised

Class B Heel Guard

RELN Storm Drain Pro™ Series 150 perfect for large domestic and light commercial applications. With its large 150mm profile, Storm Drain Pro™ effectively collects and distributes substantial volumes of surface water throughout its system. The channels innovative design features an integral side flange to create corners and intersections, removing the need to source additional fittings.



Product Specifications

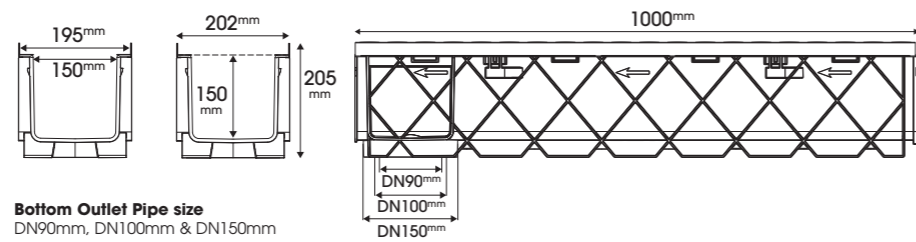

Bottom Outlet Pipe size
DN90mm, DN100mm & DN150mm

Series 150 1m Channel c/w Gal Class B Grate
Product Code: 210010
Series 150 1m Channel c/w H/Guard Class B Grate
Product Code: 210012



Product Accessories



Leaf Guard
Product Code: 210003



Series 150 End Cap
Product Code: 210002



Trade Range Series 200

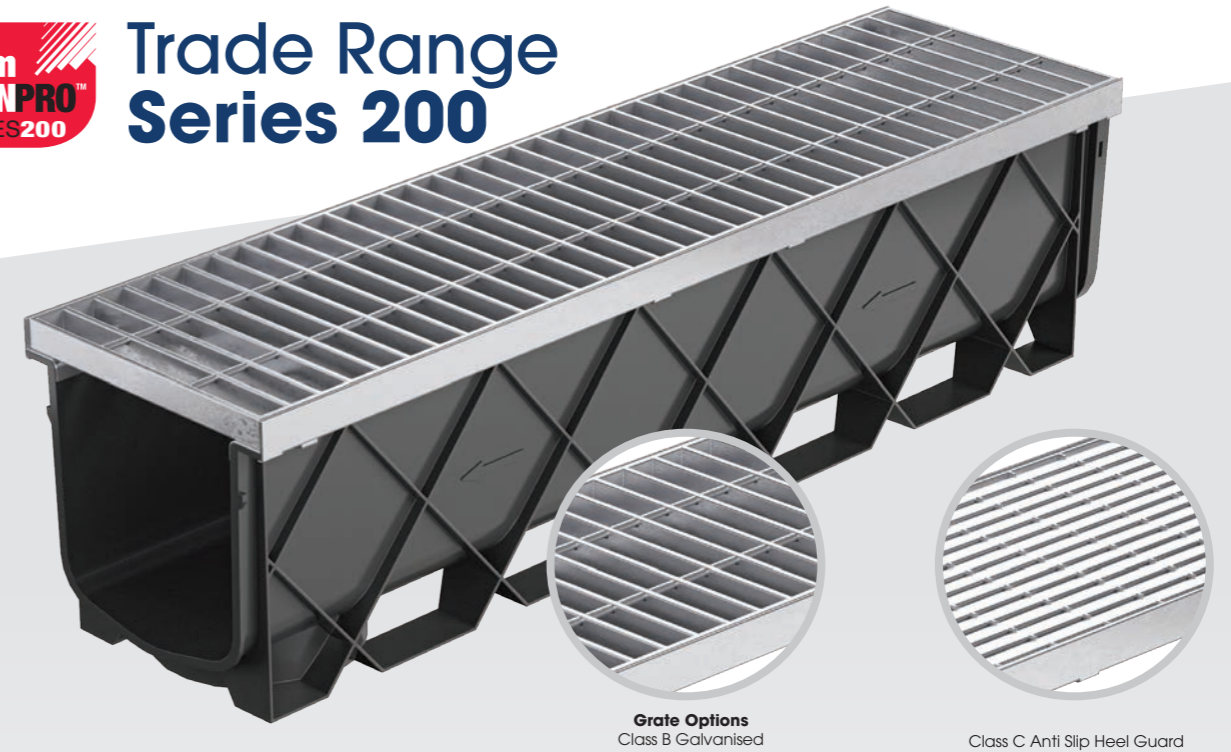

Grate Options
Class B Galvanised

Class C Anti Slip Heel Guard

RELN Storm Drain Pro™ Series 200 is the commercial surface drainage solution, perfect for heavy-use commercial applications, where heavy surface water flows or heavy vehicle and pedestrian traffic is a factor. With its large 263mm profile, Storm Drain Pro™ Series 200 effectively collects and distributes substantial volumes of surface water throughout its system. The range is strong, durable and can withstand 10 tonne of vehicle weight when installed correctly, being the master when it comes to commercial surface drainage.



Product Specifications

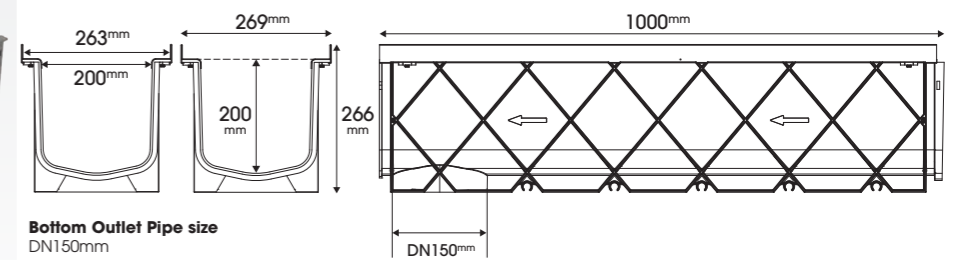

Bottom Outlet Pipe size
DN150mm

Series 200 1m Channel c/w Gal Class B Grate
Product Code: 210071
Series 200 1m Channel c/w H/Guard Class C Grate
Product Code: 210073



Product Accessories



Series 200 Inline Pit c/w Gal Class B Grate
Product Code: 210075



Series 200 Corner c/w Gal Class B Grate
Product Code: 210079

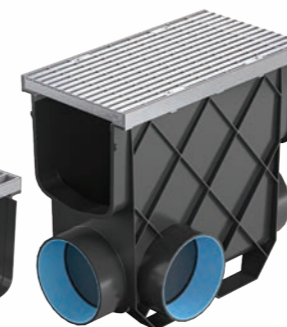

Series 200 Inline Pit c/w H/Guard Class C Grate
Product Code: 210077



Series 200 Corner c/w H/Guard Class C Grate
Product Code: 210081



Leaf Guard
Product Code: 210003



Series 200 End Cap
Product Code: 000153