

EASY INSTALL

AVAILABLE  
NOW

# RELN

HIDDEN CHANNEL™



17mm (Tile)

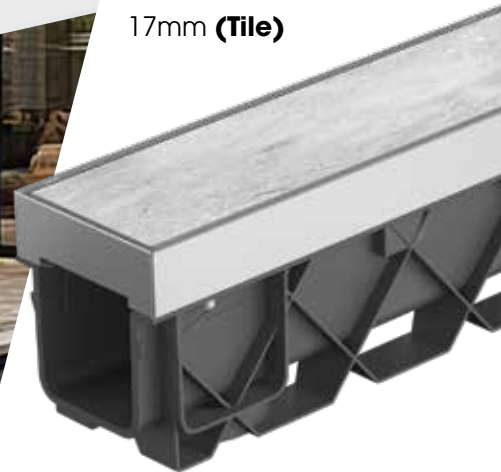

35mm (Stone)



60mm (Paver)

5  
YEAR  
CHANNEL

1  
YEAR  
GRATE

PRODUCT  
WARRANTY



RECYCLED  
PLASTIC



AUSTRALIAN  
MADE & OWNED

This product is protected by various forms of Intellectual Property

VISIT OUR WEBSITE FOR MORE  
INFO [AQUALINE.CO.NZ](http://AQUALINE.CO.NZ)

0800 889 914  
ENQUIRIES@AQUALINE.CO.NZ

**AQUALINE**

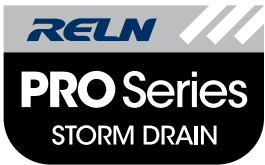

# RELN HIDDEN CHANNEL™

## > 60mm Paver

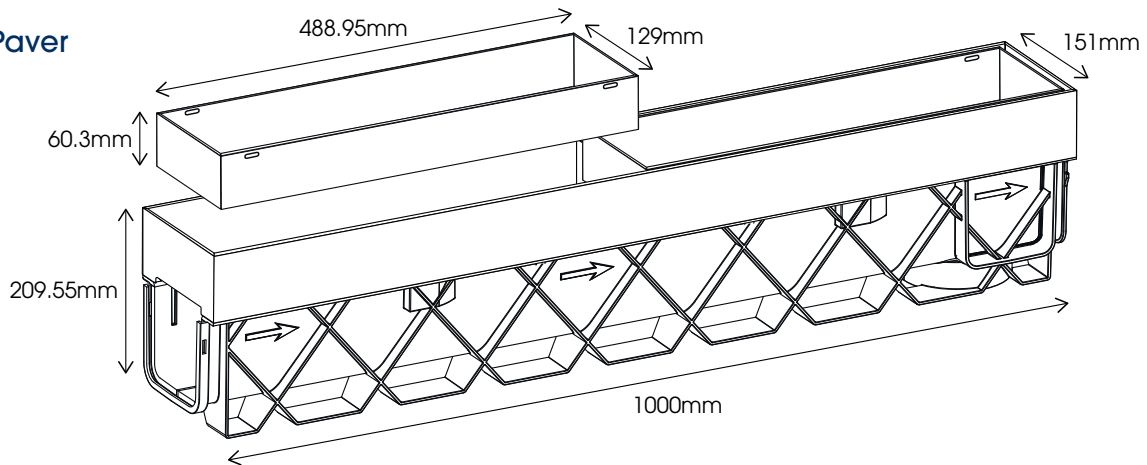

## > 17mm Tile

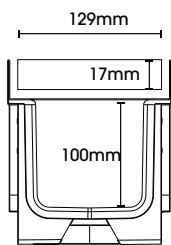
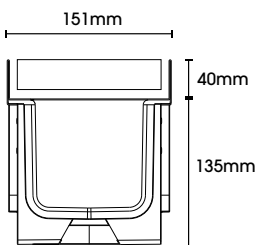

## > 35mm Stone

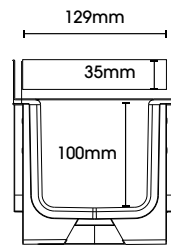
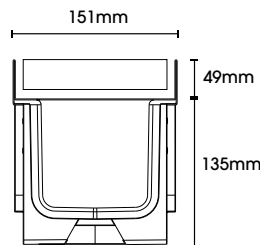

## > 60mm Paver

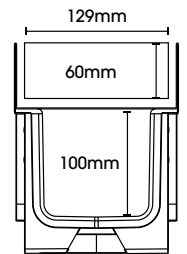
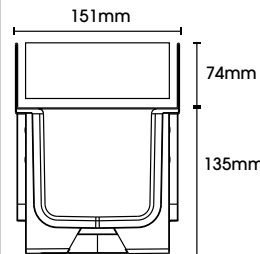

	> 17mm Tile	> 35mm Stone	> 60mm Paver
<b>Code</b>	210050	210051	210052
<b>External Size mm</b>	L 1000 x W 151 x D 40	L 1000 x W 151 x D 49	L 1000 x W 151 x D 74
<b>Internal Size mm</b>	L 1000 x W 129 x D 17	L 1000 x W 129 x D 35	L 1000 x W 129 x D 60
<b>Weight</b>	5kg	5.5kg	7kg
<b>Capacity</b>			
<b>Applications</b>	Patios , Courtyards, Pool Surrounds, Walkways , Alfresco Settings		
<b>Load Ratings</b>	CLASS >R	CLASS >R	CLASS >R

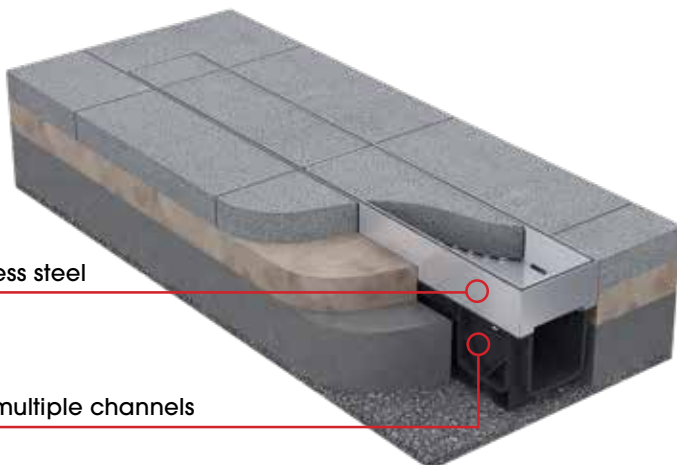

316 Stainless steel

Connect multiple channels

**Disclaimer:** Products in this specification must be installed by licensed and registered trade people. The manufacturer/ distributor reserves the right to vary specifications or delete models from their range without prior notification. Dimensions and set outs listed are correct at the time of publication however the manufacturer/distributor takes no responsibility for printing errors.

This product is protected by various for