

CIVIL EDGE PIT™ Series 600

> Civil Stormwater Pits, designed for Trade

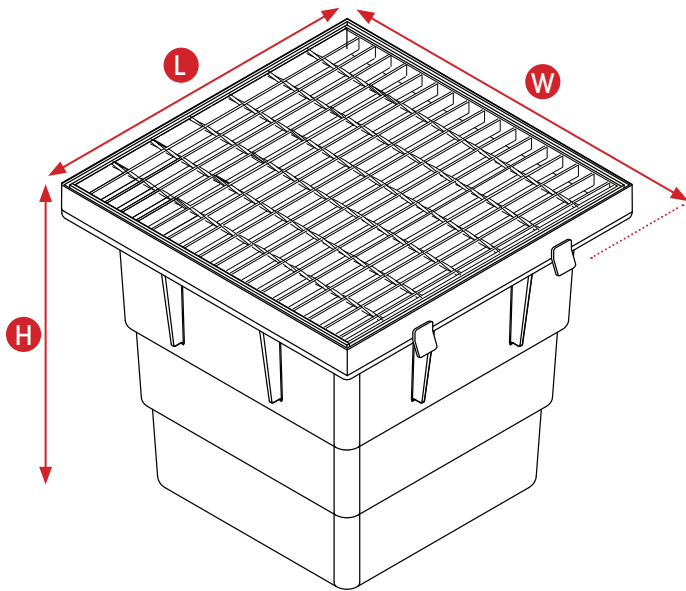

External Dimensions

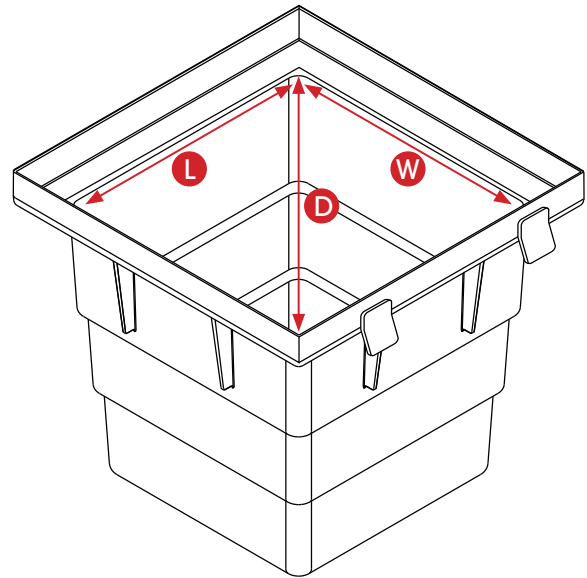

Internal Dimensions

Length (L)	Width (W)	Height (H)	Length (L)	Width (W)	Depth (D)
718mm	757mm	658mm	600mm	600mm	600mm

CivilEdge Pit Series **600**
Large Capacity Specified Drainage

Weight	23 kg		
Pit Base W/ Frame Code	001162		
Load Ratings	 CLASS A CLASS B CLASS C CLASS D		
Metal Grate Options	 Galvanised	 Anti-Slip Heelguard	 Checker Plate
Class A Product Code	001120	001146	001092
Class B Product Code	001118	001147	001142
Class C Product Code	001158		
Class D Product Code	001159		



Disclaimer: Products in this specification manual must by regulation be installed by licensed and registered trade people. The manufacturer/distributor reserves the right to vary specifications or delete models from their range without prior notification. Dimensions are nominal measurements only. Dimensions and set-outs listed are correct at time of publication however the manufacturer/distributor takes no responsibility for printing errors