

CIVIL EDGE PIT™ Series 450

> Civil Stormwater Pits, designed for Trade

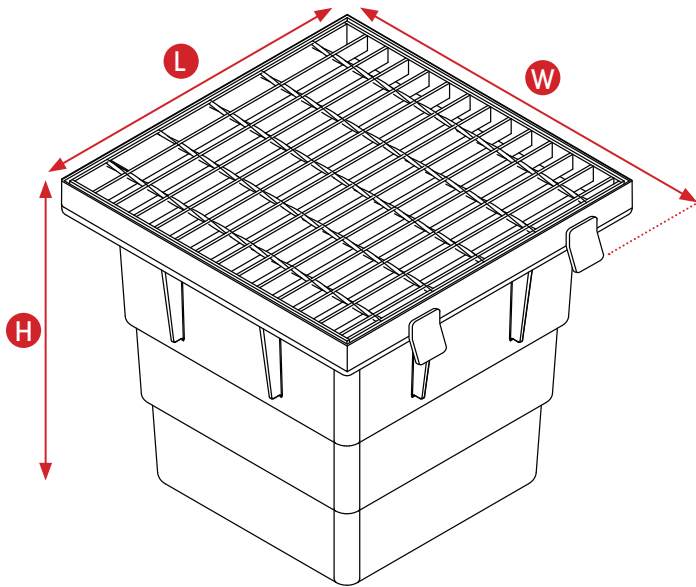

External Dimensions

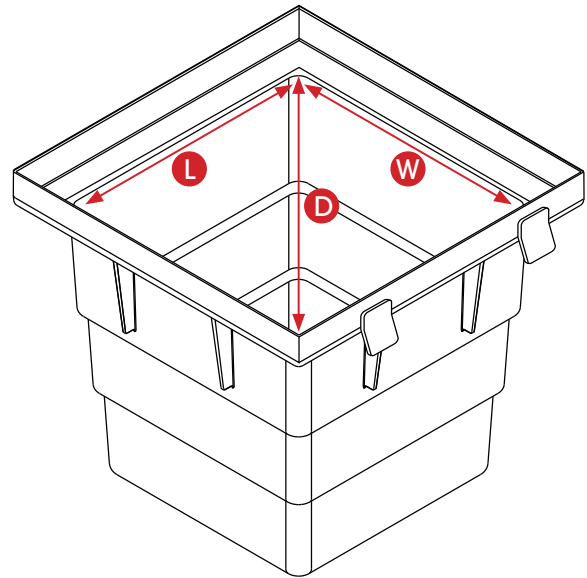

Internal Dimensions

Length (L)	Width (W)	Height (H)	Length (L)	Width (W)	Depth (D)
559mm	598mm	506mm	450mm	450mm	450mm

CivilEdge Pit Series 450
Medium Capacity Specified Drainage

Weight	14 kg		
Pit Base w/ Frame Code	000623		
Load Ratings	 CLASS A CLASS B CLASS C CLASS D		
Metal Grate Options	 Galvanised	 Anti-Slip Heelguard	 Checker Plate
Class A Product Code	001112	001144	
Class B Product Code	001113	001145	001091
Class C Product Code	000628		
Class D Product Code	000629		



Disclaimer: Products in this specification manual must by regulation be installed by licensed and registered trade people. The manufacturer/distributor reserves the right to vary specifications or delete models from their range without prior notification. Dimensions are nominal measurements only. Dimensions and set-outs listed are correct at time of publication however the manufacturer/distributor takes no responsibility for printing errors