

RELN COMMERCIAL HEAVY DUTY PITS

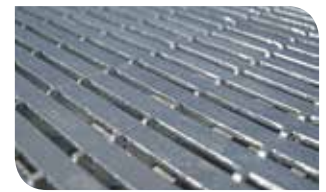

Heavy Duty Commercial Pits

- Ideal for driveways, carparks and any trafficable areas
- Easy to maintain
- Lock down security grate kits available for Series 450/600
- Australian Made from 100% recycled plastic
- Class A and B grates available & comply to Australian Standards



Large range of grates available, including NEW Anti-Slip Heel Guard Galvanised Steel grate (above), to suit your needs

Series 410



410 Series also available as a RELN Nviro Pit, suitable for domestic stormwater lines where silt and leaves need to be prevented from entering the environment

Series 450



Lock down security kits available for Series 450/600

Series 600



Super-strong, light-weight base made from structurally foamed polypropylene



Heavy Duty Commercial Pits

RELN Heavy Duty Commercial Traditional Pits is a complete range of square and environmental pits with conventional and security grates to suit every heavy commercial application. The range has been designed as a total solution to the environmental and safety hazards commonly associated with commercial drainage.

> Series 410 - Capacity: 75L (460 x 460 x 625mm)

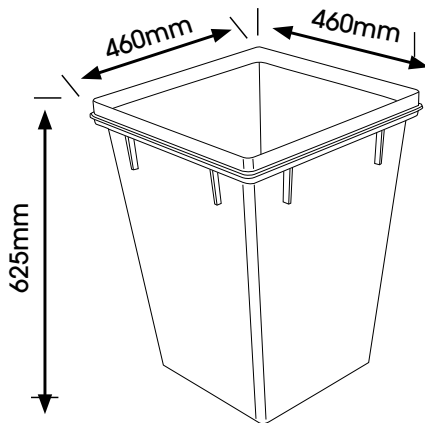

- Ideal for driveways and car parks
- Deep commercial pit
- Preferred where plenty of fall in the stormwater pipes is required

Grate Options: (435 x 435 x 20mm)
Light Duty Galvanised Steel Class A, Anti-Slip Heel Guard Galvanised Steel Class A, Medium Duty Galvanised Steel Class B, Medium Duty Galvanised Steel Checker Plate Cover Class B

Risers: Height 350mm

Accessories: Galvanised Trash Screen with handle.

Display: Brochure Available

> Series 450 - Capacity: 76L (560 x 560 x 510mm)

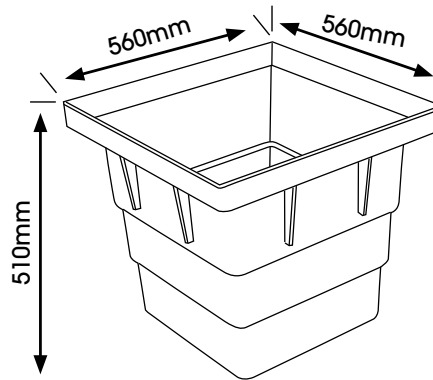

- Ideal for driveways, car parks and any trafficable areas
- Medium heavy duty commercial Pit

Grate Options: (540 x 540 x 50mm)
Light Duty Galvanised Steel Class A, Light Duty Heel Guard Galvanised Steel Class A, Medium Duty Anti-Slip Galvanised Steel Class B, Medium Duty Anti-Slip Heel Guard Galvanised Steel Class B, Medium Duty Galvanised Steel Checker Plate Cover Class B

Risers: Height 300mm

Accessories: Galvanised Trash Screen with handle, Series 450/600 Pit Grate Security Kit

Display: Brochure Available

> Series 600 Deep - Capacity: 175L (710 x 710 x 660mm)

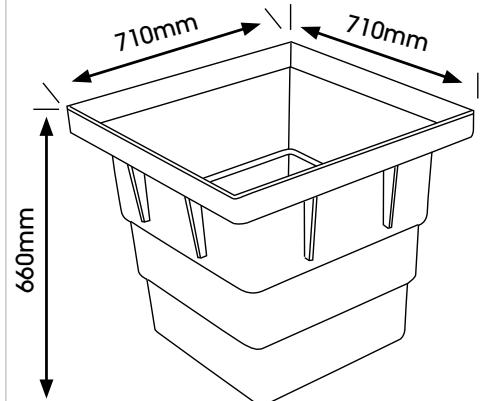

- Ideal for driveways, car parks and trafficable areas
- Large heavy duty commercial pit
- Ideal junction box where large bore pipe is used

Grate Options: (685 x 685 x 50mm)
Light Duty Anti-Slip Galvanised Steel Class A, Light Duty Galvanised Steel Class A, Medium Duty Galvanised Steel Class B, Medium Duty Anti-Slip Heel Guard Galvanised Steel Class B, Medium Duty Galvanised Steel Checker Plate Class B

Risers: Height 300mm

Accessories: Galvanised Trash Screen with handle, Series 450/600 Pit Grate Security Kit

Display: Brochure Available

> Frequently Asked Questions

Q1. What does the Nviro Pit do?

A. The RELN Nviro Pit protects our stormwater systems, wetlands, rivers and watercourses from pollutants, plastic bags, cigarette butts and aluminium cans entering the stream.

Q2. What does the Nviro Pit come with?

A. The RELN Nviro Pit comes with pit base, inner basket and diffuser with either a Light Duty Class A Galvanised grate or a Medium Duty Class B Galvanised grate.

Q3. What size pipes can connect to the pits?

A. Traditional Pits run on a horizontal pipework and can connect to 90mm and 100mm PVC pipe. (Larger PVC stormwater pipes can run through the pits, just cut hole to size).

Q4. What Risers are available?

A. Risers are available for Series 300 (short and deep), 410, 450, 600 Pits. Series 250 Pit uses another Series 250 Pit with bottom cut out. Uni-Pit Vortex require no risers as they connect to vertical pipework. Polymer Concrete pits have their own risers.

Q5. How do I fit the PVC pipe to the Traditional Pits?

A. Use silicon to seal and secure pipework to Traditional Pits. Only Uni-Pit Vortex can be easily secured with silicon glue as well.

Q6. What is the load rating of the grates?

A. See our Class Load Rating table for more information.

